

DESCRIPTION

The PT2399 is a single chip echo processor IC utilizing CMOS technology. Which accept analog audio input signal, a high sample rate ADC transfer the analog signal into a bit stream then storage to internal 44Kbit RAM, after processing the bit stream will de-modulate by DAC and lowpass filter. Overall delay time is determined by internal VCO clock frequency, and user can easy to change the VCO frequency by changing the external resistance. The PT2399 performs low distortion (THD<0.5%@0.5Vrms) and low noise (No<-90dBV) characteristic for audio purpose, and pin arrangement and application circuit are optimized for easy PCB layout and cost saving advantage.

FEATURES

- CMOS technology
- Least external components
- Auto reset Function prevent POP noise
- Low noise, SNR better than 90dB (typical)
- Low distortion, THD= 0.5%(typical)
- User adjustable VCO clock frequency.

APPLICATIONS

- KARAOKE Mixer
- CD/DVD Player/Recorder
- Multimedia TV
- Car Entertainment System
- Music Instrument effector
- Electronics Toy

BLOCK DIAGRAM

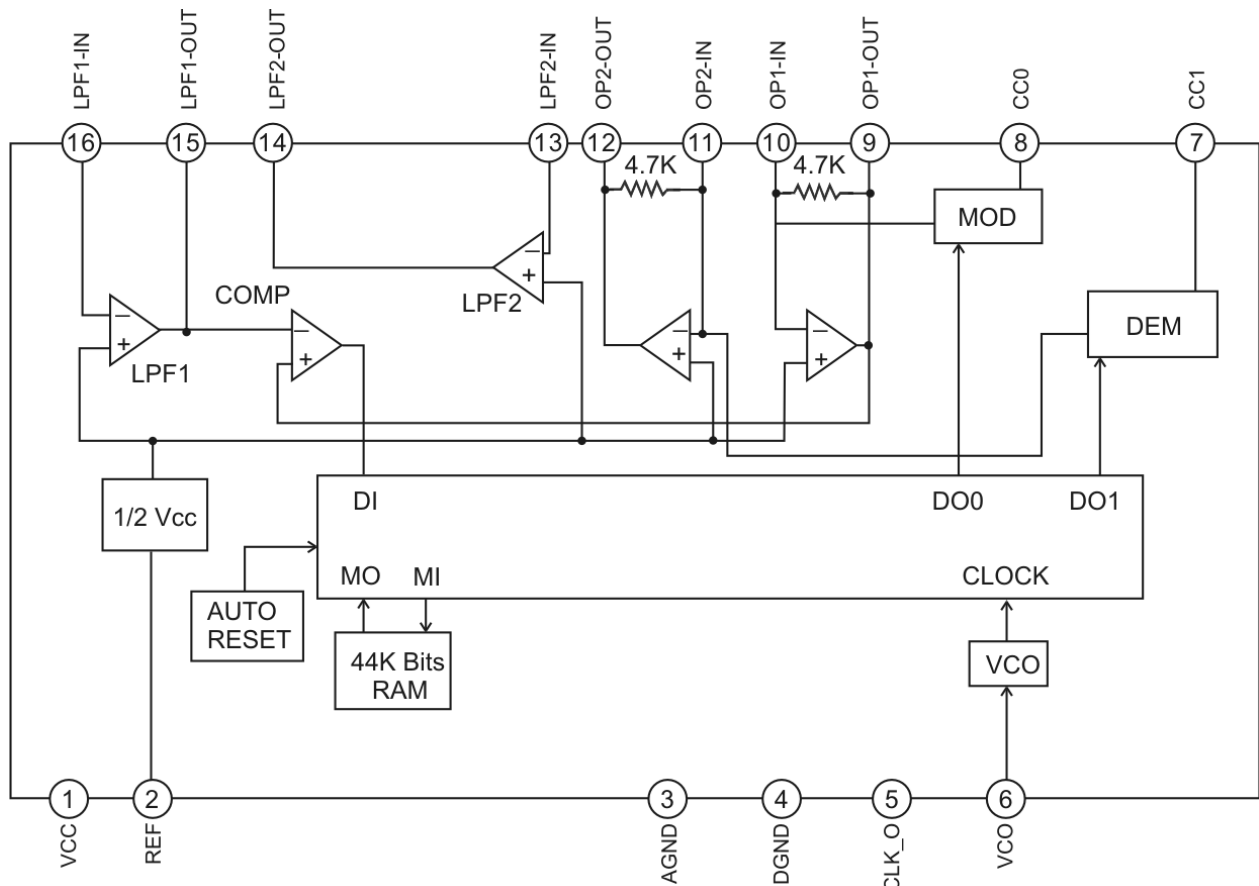

APPLICATION CIRCUIT

ECHO

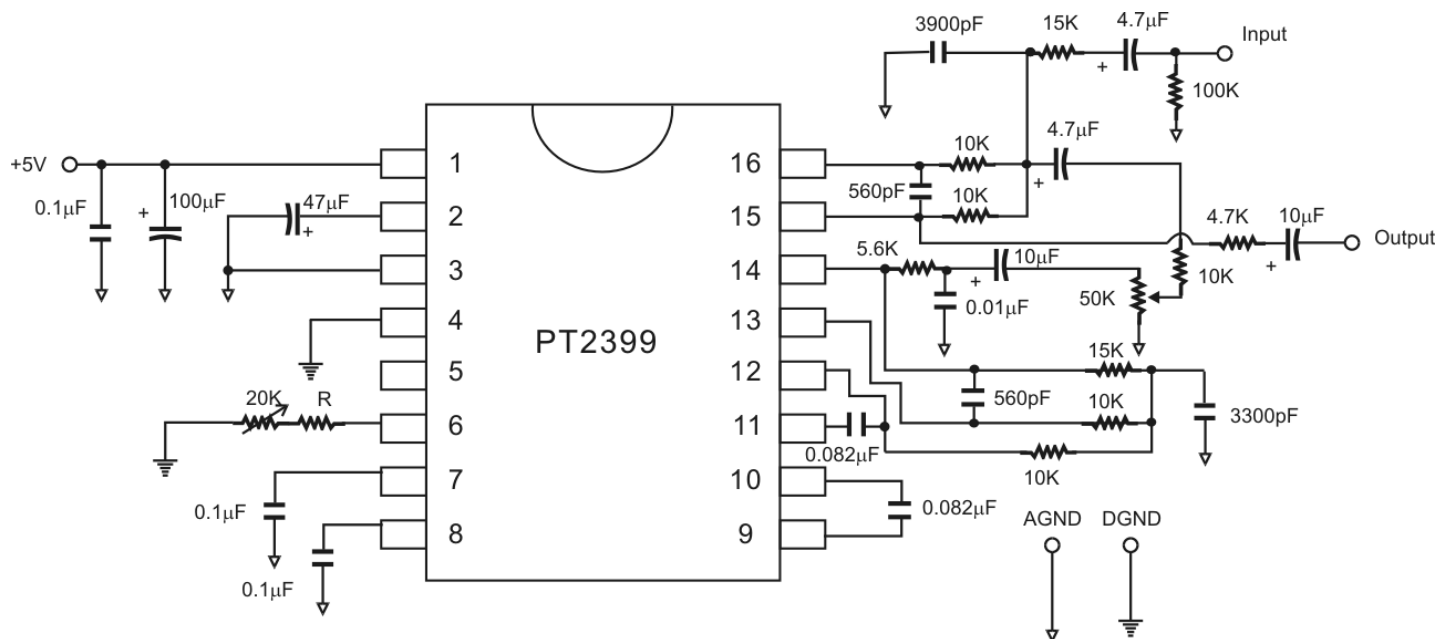

Note:
 External Resistor having a value of 10 KΩ to 50 KΩ may be used. The recommended Resistor Value(R) is 10 KΩ. When the value of the Resistor (R) increases, the range of the Delay Time also increases.

SURROUND/DELAY

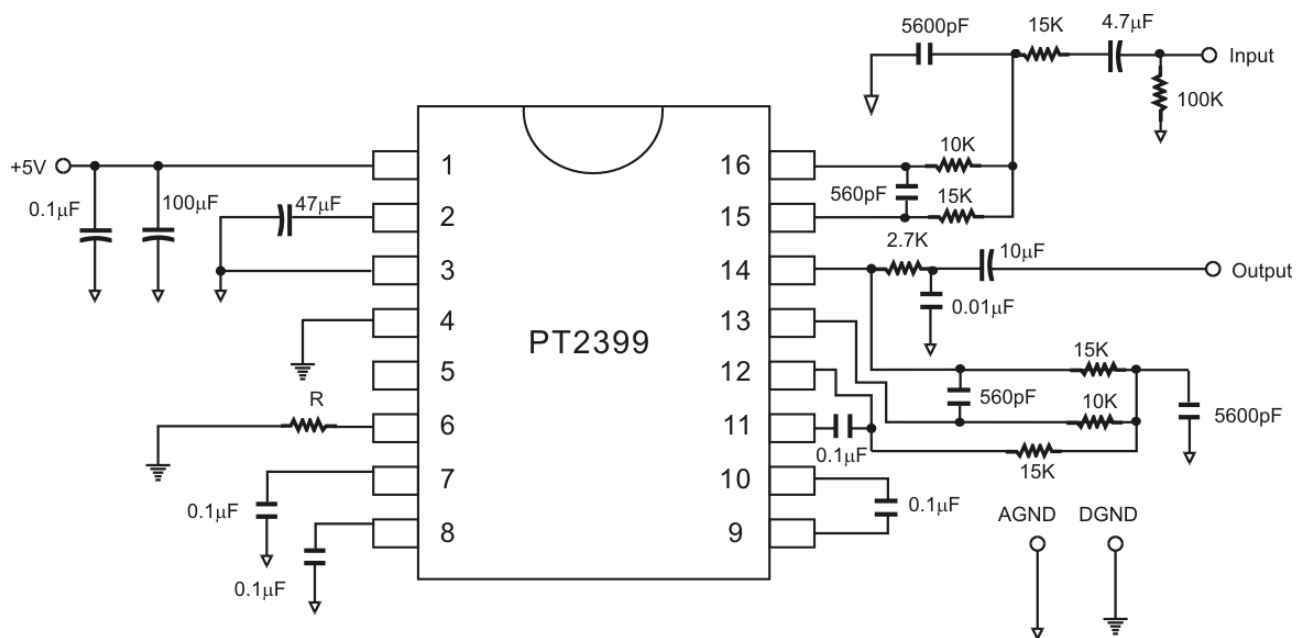

Note: Please refer to Table 1 for the Resistor/Delay Time values.

ORDER INFORMATION

Valid Part Number	Package Type	Top Code
PT2399	16 Pins, DIP, 300mil	PT2399
PT2399S	16 Pins, SOP, 300mil	PT2399S
PT2399-SN	16 Pins, SOP, 150mil	PT2399-SN

PIN CONFIGURATION

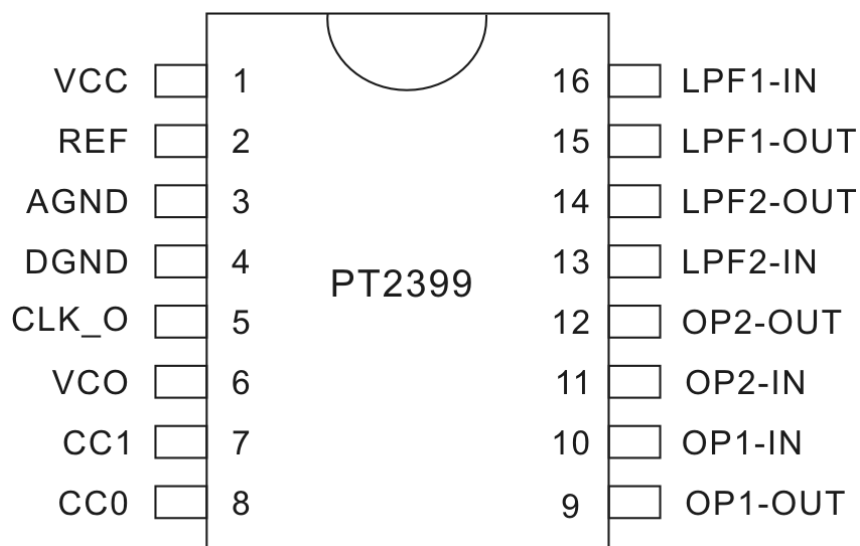

PIN DESCRIPTION

Pin Name	I/O	Description	Pin No.
VCC	-	Analog supply voltage input	1
REF	-	Analog reference voltage (1/2VCC)	2
AGND	-	Analog ground	3
DGND	-	Digital ground	4
CLK_O	O	System clock output pin	5
VCO	I	VCO Frequency adjustment	6
CC1	-	Current control 1	7
CC0	-	Current control 0	8
OP1-OUT	O	OP amplifier 1 input/output. This pin can be used as modulated/Demodulated integrator by connecting capacitor	9
OP1-IN	I		10
OP2-IN	I	OP Amplifier 2 input/output. This pin can be used as Modulated/Demodulated Integrator by connecting Capacitor	11
OP2-OUT	O		12
LPF2-IN	I	Low pass filter 2 input/output pin	13
LPF2-OUT	O		14
LPF1-OUT	O	Low pass filter 1 input/output pin	15
LPF1-IN	I		16

FUNCTION DESCRIPTION

ECHO MODE

Please refer to the diagram below:

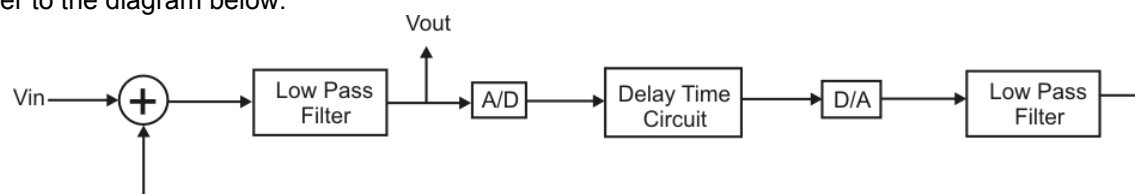

AUTO RESET FUNCTION

The waveform of the signal during power on is given below:

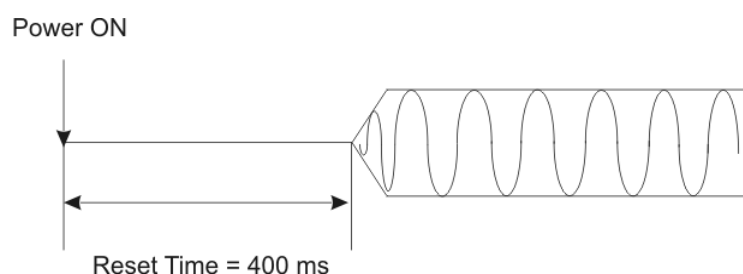

TABLE 1: VCO FREQUENCY VS DELAY TIME

R	27.6K	21.3K	17.2K	14.3K	12.1K	10.5K	9.2K	8.2K
fck	2.0M	2.5M	3.0M	3.5M	4.0M	4.5M	5.0M	5.5M
td	342ms	273ms	228ms	196ms	171ms	151ms	136.6ms	124.1ms
THD	1.0%	0.8%	0.63%	0.53%	0.46%	0.41%	0.36%	0.33%

R	7.2K	6.4K	5.8K	5.4K	4.9K	4.5K	4K	3.4K
fck	6.0M	6.5M	7.0M	7.5M	8.0M	8.5M	9.0M	10M
td	113.7ms	104.3ms	97.1ms	92.2ms	86.3ms	81ms	75.9ms	68.1ms
THD	0.29%	0.27%	0.25%	0.25%	0.23%	0.22%	0.21%	0.19%

R	2.8K	2.4K	2K	1.67K	1.47K	1.28K	1.08K	894
fck	11M	12M	13M	14M	15M	16M	17M	18M
td	61.6ms	56.6ms	52.3ms	48.1ms	45.8ms	43ms	40.6ms	38.5ms
THD	0.18%	0.16%	0.15%	0.15%	0.15%	0.15%	0.14%	0.14%

R	723	519	288	0.5
fck	19M	20M	21M	22M
td	36.6ms	34.4ms	32.6ms	31.3ms
THD	0.14%	0.13%	0.13%	0.13%

Notes:

1. R = VCO External Resistor (Ω), please refer to PT2399 Application Circuit.
2. fck = VCO Clock Frequency (Hz).
3. td = Delay Time
4. THD = Total Harmonic Distortion
5. We do not recommend the "R" value below 1K Ω when power on.

ABSOLUTE MAXIMUM RATING

(Unless otherwise specified, Ta=25°C)

Parameter	Symbol	Rating	Unit
Supply voltage	Vcc	6.5	V
Supply current	Icc	100	mA
Power dissipation	Pd	1.7	W
Operation temperature	Topr	-40 to +85	°C
Storage temperature	Tstg	-65 to +150	°C

RECOMMENDED OPERATING CONDITIONS

Parameter	Symbol	Min.	Typ.	Max.	Unit
Supply voltage	Vcc	4.5	5	5.5	V
Clock frequency	fck	-	4	5	MHz

AC CHARACTERISTICS

(Unless otherwise specified: Vcc=5.0V, fin=1KHz, Vi=500mVrms, fck=4MHz, Ta=25°C)

Parameter	Symbol	Test Condition	Min.	Typ.	Max.	Unit
Supply voltage	Vcc	-	4.5	5.0	5.5	V
Supply current	Icc	-	-	15	30	mA
Voltage gain	Gv	RL=47KΩ	-	-0.5	2.5	dB
Max. output voltage	Vomax	THD=10%	1	1.25	1.5	Vrms
Output distortion	THD	A-weighted	-	0.4	1.0	%
Output noise voltage	No	A-Weighted	-95	-90	-80	dBV
Power supply rejection ratio	PSRR	Vr=100mV, f=100Hz	-	-40	-30	dB

PACKAGE INFORMATION

16 PINS, DIP, 300 MIL

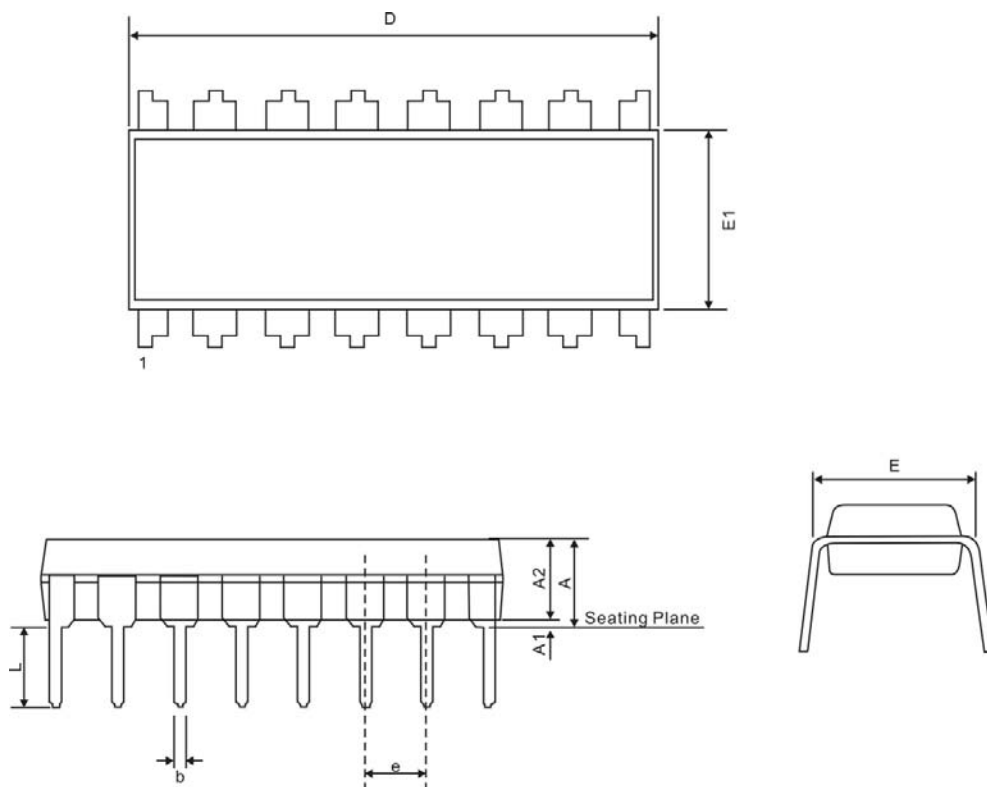

Symbols	Dimensions		
	Min.	Nom.	Max.
A	-	-	5.33
A1	0.38	-	-
A2	2.92	3.30	4.95
b	0.36	-	0.56
D	18.67	19.17	19.69
E	7.62 BSC		
E1	7.62	7.87	8.26
e	2.54 BSC		
L	2.92	-	3.81

Notes:

1. Refer to JEDEC MS-001 Variation BB
2. Unit: mm

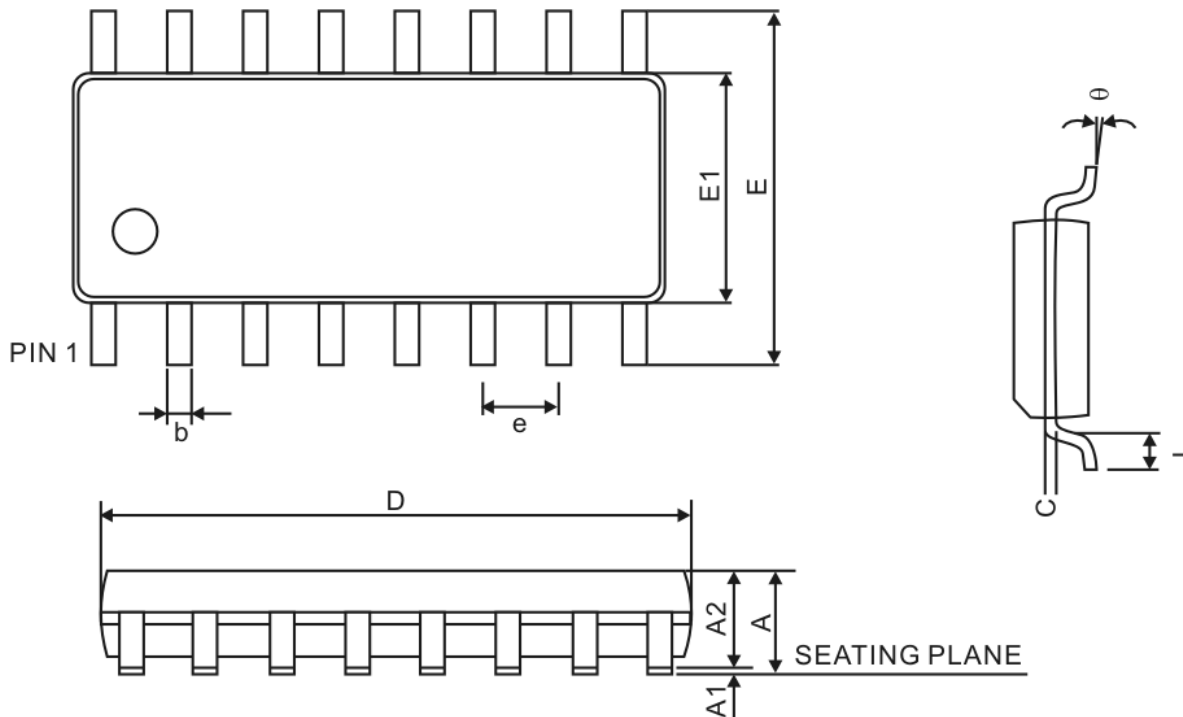
16 PINS, SOP, 300 MIL

Symbol	Min.	Nom.	Max.
A	-	-	2.65
A1	0.10	-	0.30
A2	2.05	-	-
b	0.31	-	0.51
c	0.20	-	0.33
D	10.30 BSC		
E	10.30 BSC		
E1	7.50 BSC		
e	1.27 BSC		
L	0.40	-	1.27
θ	0°	-	8°

Notes:

1. Refer to JEDEC MS-013AA
2. Unit: mm

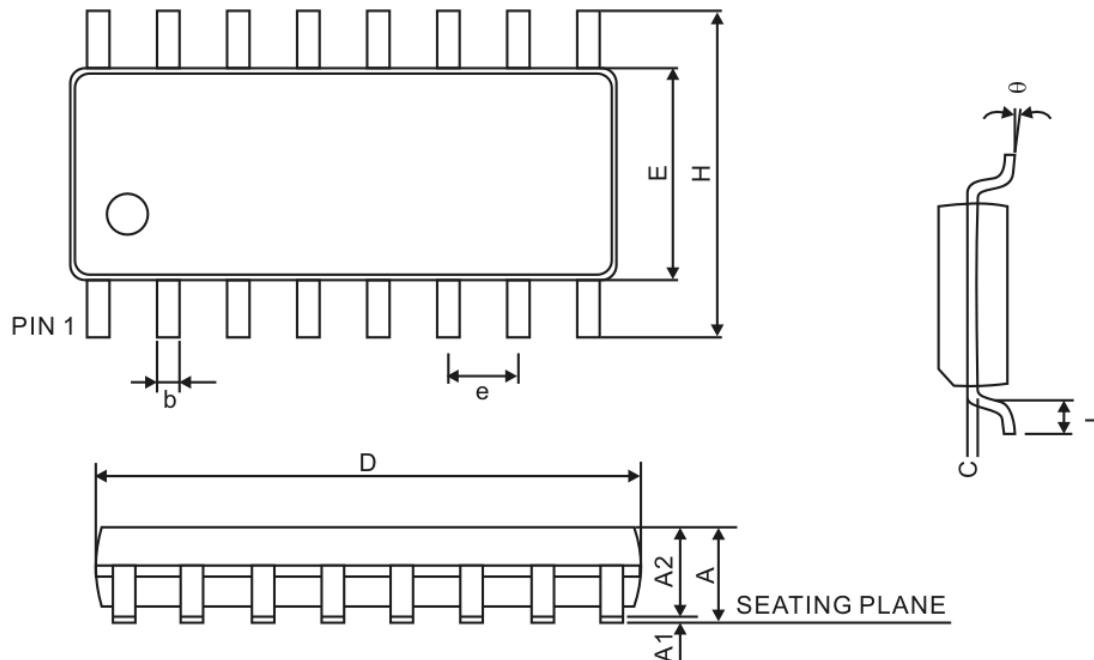
16 PINS, SOP, 150MIL

Symbol	Min.	Nom.	Max.
A	1.35	-	1.77
A1	0.08	-	0.28
A2	1.20	1.45	1.65
b	0.31	-	0.51
c	0.16	-	0.26
D	9.90 BSC		
E	3.90 BSC		
H	6.00 BSC		
e	1.27 BSC		
L	0.40	-	1.27
θ	0°	-	8°

Notes:

3. Refer to JEDEC MS-012AC

4. Unit: mm

IMPORTANT NOTICE

Princeton Technology Corporation (PTC) reserves the right to make corrections, modifications, enhancements, improvements, and other changes to its products and to discontinue any product without notice at any time.

PTC cannot assume responsibility for use of any circuitry other than circuitry entirely embodied in a PTC product. No circuit patent licenses are implied.